



*Emflux M300
Flowmeter Transmitter*

A comprehensive range of electromagnetic flowmeters to suit applications from water to abrasive and corrosive process fluids.

Features

- The M300 uses the well proven electromagnetic method of measurement, which applies Faraday's Law as the principle of operation. This technique features a straight through section of pipe with no obstruction to restrict flow and no moving parts to wear or break.
- Highly accurate. 0.2 % of rate from 0.5 to 10 metres (1.65 to 33 feet) per second.
- Integral keypad standard. All configuration is performed via front keypad. No plug-in programmer required.
- 32 character display standard, displays rate, total and diagnostic messages.
- Display guides operator with menu prompts during configuration.
- Comprehensive output options. Include multiple analogue, relay, digital and serial outputs.
- Self calibrating system with in-field verification.
- Self monitoring and diagnostic functions. Constantly monitors system integrity and measurement validity. Diagnostics can be linked to outputs for diagnostic alarm.
- Flexible mounting options. Wall or panel mounting system standard.
- Bi-directional flow standard.
- Accredited under the Standards Australia Supplier Assessment scheme to ISO9002, ensuring our customers receive a high level of support and quality.

General Applications

Electromagnetic flowmeters for the accurate flow measurement of any conductive fluid. Ideally suited to water and waste water treatment plants, mining and general industry.

Technical Data

Display: 32 character (2 line x 16 character) alphanumeric backlit LCD. Displays rate of flow, total flow, alarms, diagnostic messages analogue outputs and relay annunciators. Displays text prompts in programming mode.

Configuration: All functions are accessible via 3 button integral keypad. A logical 2 level menu system with display prompts ensures ease of configuration.

Outputs: 1 x 4 - 20 mA. Second 4 - 20 mA output optional. (Each fully isolated, max. load 1000 ohms) 2 x relays with change over contacts. 4 x relays optional. (1.0 A, 30 VDC. Selectable for dry contact). Configurable for:

- Empty pipe detection (Note: Requires detector with 'pipe not full' option)
- Forward/reverse flow detection
- Hi/low alarm, (deadband adjustable)
- Totaliser output
- System fault, diagnostic alarm.

2 x Digital, open collector. (Configurable as frequency [0 - 1000 hz] or pulse outputs 100 mA, 60VDC). 1 x RS485/RS232.

Power supply: 24 VDC. 85 - 265 VAC 50/60Hz. ($\pm 20\%$). Power consumption, 25 va.

Enclosure: Rated IP65 (Nema 4). Surface or panel mounting.

Accuracy: $\pm 0.2\%$ of rate or ± 0.001 metres (± 0.003 feet) per second, whichever is greater, from 0.5 to 10 metres (1.65 to 33 feet) per second.

Battery operation: The M300 can function from a 24VDC battery power supply. The M300 will take a reading from the flowtube, turn off the power supply to the tube, and hold this reading, indicating and totalising at this rate for the 'switch off'. This switch off period is adjustable to suit the particular dynamics of the flow application, and maximise battery life. Two 60AH 12V batteries will power the flowmeter for a period of 2 weeks, based on a 10 min update time. Using a solar panel the system can run continuously without mains power.

Velocity/Accuracy Graph

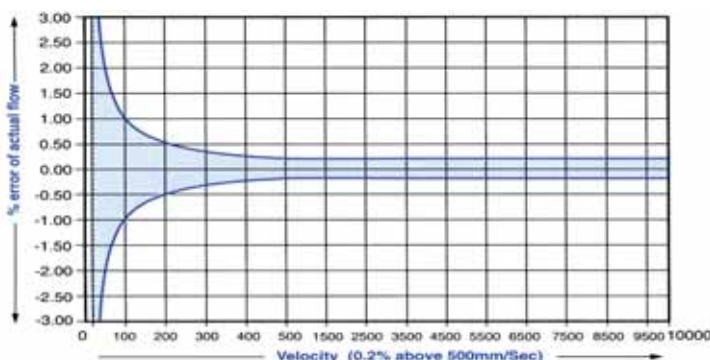

Resolution	18 bit.
Linearity	< 0.05%
Repeatability	< 0.05%
Temp, stability	< 0.05% range, minus 10-55°C (14-131°F)
Voltage effects	Negligible
Turndown from FS	> 1000:1
Separation	100 metres (328 feet).
Conductivity	5 μ S/cm.

Set-up and Operation

The operation and set-up of the system are broken into two main areas:

Commissioning Mode

Only accessible through a 3 digit security code to avoid unauthorised access. This mode is used to set the Flow System to your application requirements, including Flow Range, Flow Units, Response Time, Simulations, Outputs etc. Settings may be made either direct via the three button keypad or remotely using the Comms Port and a computer. When information is provided, the M300 is supplied configured to customer requirements.

Operations Menu

Displays readings in normal run mode. The default display shows the Flowrate and Totaliser with an indication of Forward / Reverse Flow. The operator may also call up other displays, using the up/down arrow key, such as

- Reverse Total
- Diagnostics and Alarms
- Rate/Velocity
- Output Signals
- Nett Totaliser
- Run Time Hours

The display automatically reverts back to default display after two (2) minutes.

Diagnostics

The M300 incorporates advanced diagnostics which monitor the integrity of the system, including:

- Detector Head Current
- Internal Reference Voltages
- Detector Head Cabling
- A to D Conversion

Configuration options

- Detector Head Size
- Detector Head Constant
- Flow range
- Response Time
- Low-flow Cut-off
- Failsafe Modes
- Relay functions
- Outputs

The LCD display and integral keypad allows the user complete control over all configurable functions. Self calibrating electronics and self diagnostics ensure the system maintains integrity at all times. Simple in-field verification available.

Operator interface

The M300 includes an integral 2 line alphanumeric display and keypad as standard. No plug in programmer is required. Password protection is included to prevent unauthorized tampering. All parameters are sequenced in a logical, easy to follow order. Configuration prompts on the display further simplifies set-up.

Automatic electrode cleaning

A high frequency applied to the Electrodes between each measurement cycle is used to continuously clean the electrodes. This feature removes the errors caused by coating which typically occurs in many applications.

Dimensions (mm)

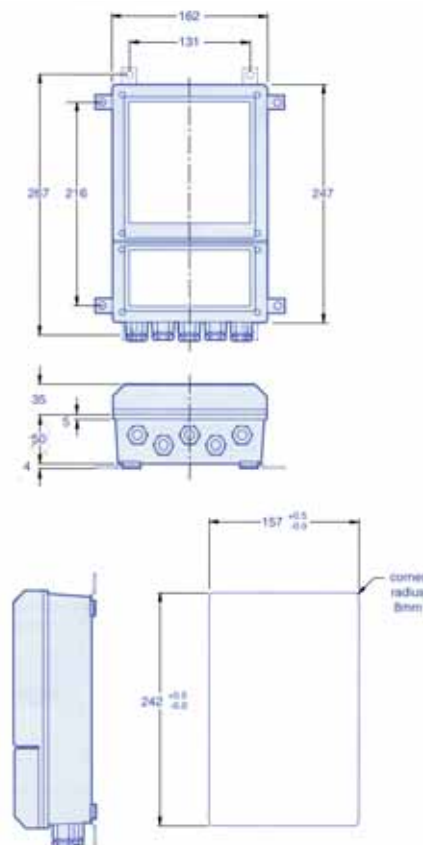

Typical specifying sequence

Example:	M300 -	L	1A	2R	F	R	K
Power Supply		↑	↑	↑	↑	↑	↑
L = 24 DC (standard)							
M = 85 to 265 VAC 50 Hz (60 Hz optional)							
Analogue output			↑	↑			
1A = 1 x 4 to 20 mA (standard)							
2A = 2 x 4 to 20 mA							
Relay outputs				↑			
2R = 2 x relays (standard)							
4R = 4 x relays							
Flowmeter type					↑		
F = Full Pipe MagFlow Tube							
Mounting options						↑	
R = Remote transmitter							
Special function							↑
K = (ie. empty pipe detection, 60 Hz line frequency)							



Australia

Head Office
Goyen Controls Co Pty Ltd
268 Milperra Road
Milperra, NSW 2214

Telephone: 1800 805 372
Facsimile: 1300 658 799

Queensland
Telephone: 1800 805 372
Facsimile: 1300 658 799

Victoria
Telephone: 1800 805 372
Facsimile: 1300 658 799

South Australia
Telephone: 1800 805 372
Facsimile: 1300 658 799

Western Australia
Telephone: 1800 805 372
Facsimile: 1300 658 799

Asia

Goyen Controls Co Pty Ltd
Shanghai Representative Office
1209 Greenland Business Centre
1258 Yu Yuan Road
Shanghai PC200050
CHINA

Telephone: +86 21 5239 8810
Facsimile: +86 21 5239 8812

Goyen Controls Co Pty Ltd
73-M Jalan Mega Mendung
Kompleks Bandar OUG
58200 Kuala Lumpur MALAYSIA

Telephone: +60 37 987 6839
Facsimile: +60 37 987 7839

Office: Singapore
Tel/Facsimile: +65 6457 4549

USA

Goyen Valve Corporation
1195 Airport Road
Lakewood
New Jersey 08701
USA

Telephone: +1 732 364 7800
Facsimile: +1 732 364 1356

Europe

Goyen Controls Co UK Ltd
Unit 3B Beechwood
Chineham Business Park
Basingstoke, Hampshire, RG24 8WA
UNITED KINGDOM

Telephone: +44 1256 817 800
Facsimile: +44 1256 843 164

Tyco Umwelttechnik GmbH
Im Petersfeld 6
D-65624 Altendiez
GERMANY

Telephone: +49 6432 95299 0
Facsimile: +49 6432 95299 24

Mecair S.r.l.
Via per Cinisello 97
20054 Nova Milanese
Milano,
ITALY

Telephone: +39 0362 3751
Facsimile: +39 0362 367279