

# OPERATING GUIDE

## *Pulse Controller 20 Series*

**Installation**

**Operation**

**Product Maintenance**

## INSTALLATION

### Mechanical Installation

View of mechanical fastening points on rear of enclosure

*Note: Figure not drawn to scale.*

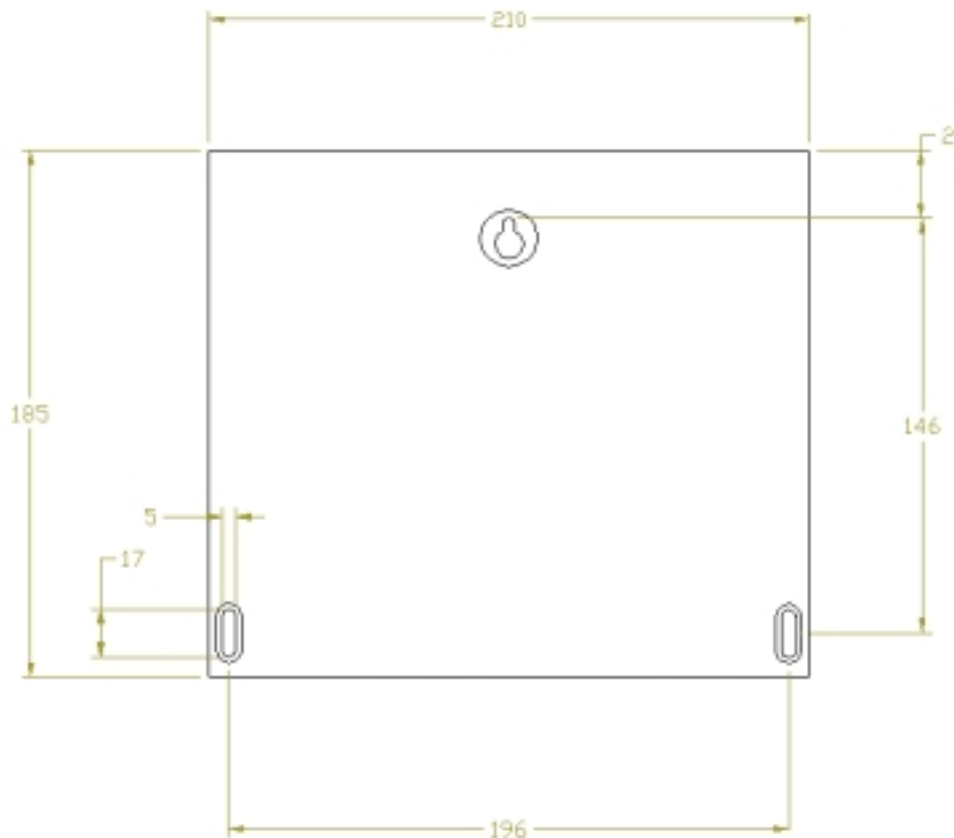

- Mount in environments of -10°C to + 50°C
- Do not mount directly to hot surfaces
- Do not expose directly to sunlight
- Protect from infiltrations of water and humidity
- Do not install on vibrating surfaces
- All electrical connections including the wiring associated with the valves should not be in close proximity to wiring for other applications (for example from motor cables)
- 3 point mounting

## Electrical Installation

### Basic Installation

Firstly, the power should be isolated from the unit, and have the power switch in the "O" (OFF) position.

**Figure 1 - Electrical circuit board with jumper selections magnified**

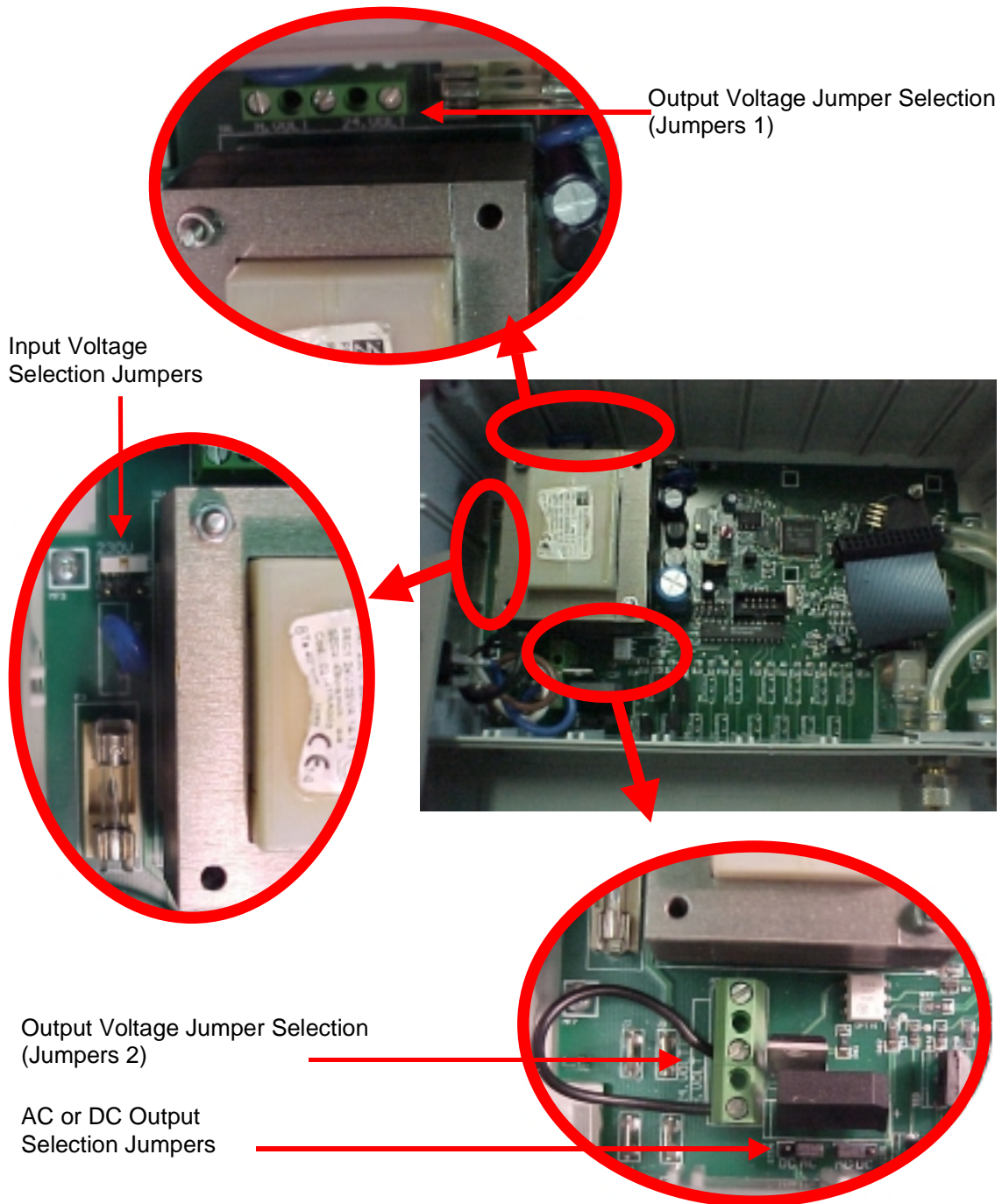

Select the input voltage being supplied to the unit by use of the jumper terminals shown in Figure 2. (Refer to Figure 1 for location on the PCB)

**Figure 2 - Possible input voltage jumper selections**

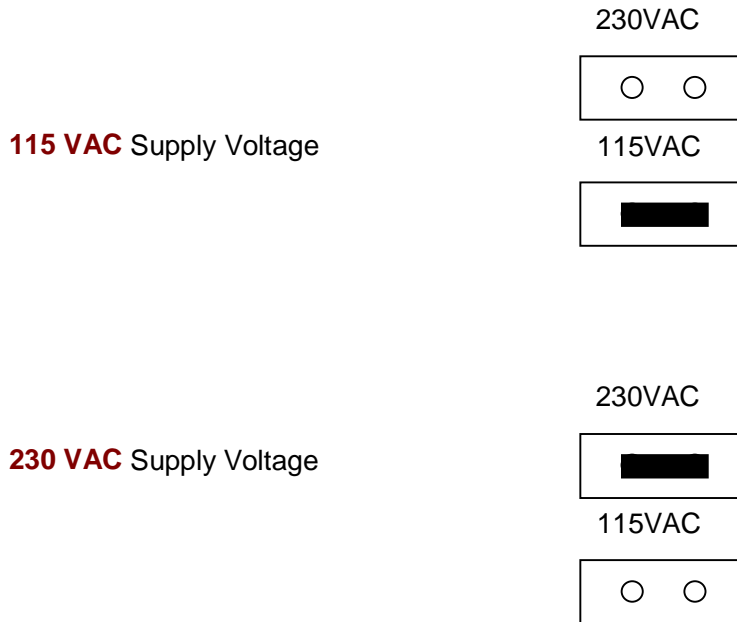

Select the output voltage being supplied to the unit by use of the jumper terminals shown in Figure 3. (Refer to Figure 1 for location on the PCB)

**Figure 3 - Possible output voltage jumper selections (jumper 1)**

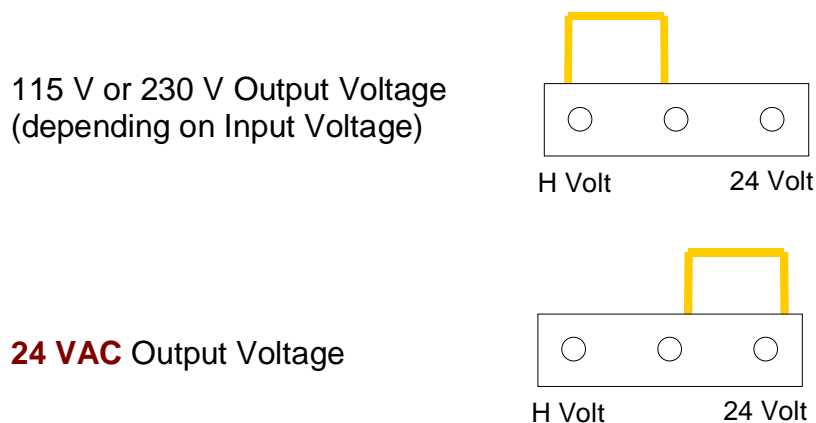

**Important Note:** It is of the utmost importance that when setting the Output Voltage for the controller, that the two (2) sets of jumpers shown in Figure 3 and 4 are both set to the same Output Voltage.

**Figure 4 - Possible output voltage jumper selections (jumpers 2)**

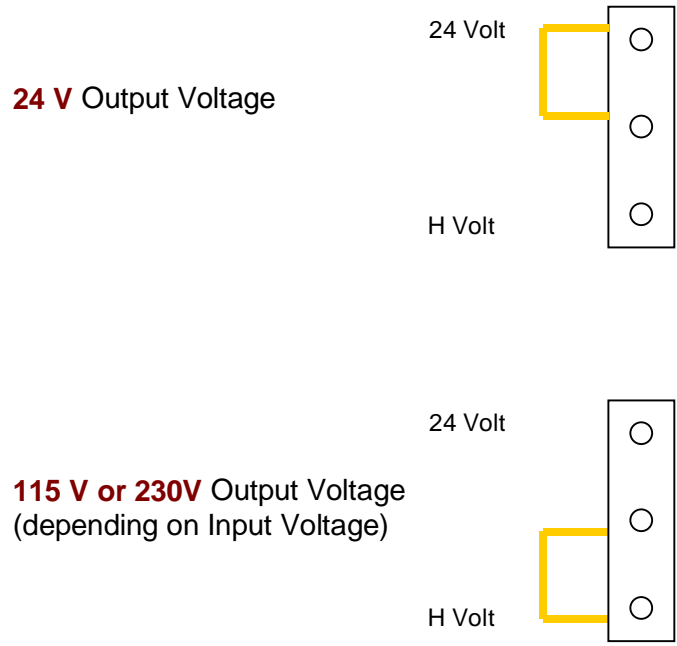

Choose whether the output is to be either AC or DC. (See Figure 5 for selections and refer to Figure 1 for location on the PCB)

**IMPORTANT NOTE: NEVER select 230V Output as DC!**

**Figure 5 - Possible AC/DC voltage output jumper selections**

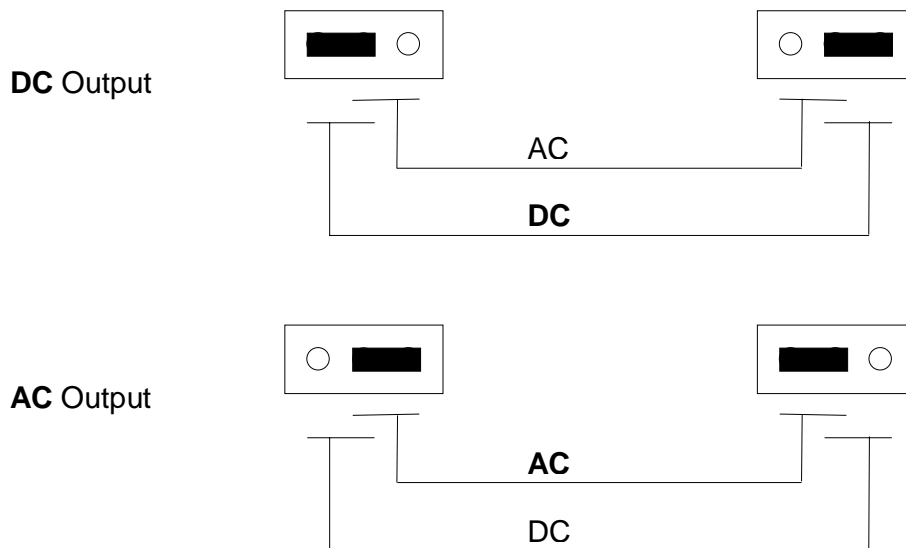

Connect the valves to the terminals shown in Figure 6.

**Figure 6 - Output terminals for solenoids**



Ensure that the unit is still isolated from the power supply.

Now connect the input power to the unit, observing that Ground (Yellow/Green wire) is connected properly, followed by Neutral (Blue wire) and finally Line (Brown wire).

When power is applied to the unit, turn the unit on ("I" Position).

### **Additional Wiring Features**

This section explains the wiring of the following features of the Goyen Pulse Controller 20 Series.

- a. Coil Failure/High dP Remote Alarm Monitoring
- b. Fan Contacts
- c. Remote Contacts

**Please Note:** the alarm contacts on the PCB are 'Dry' contacts with relay outputs (otherwise known as 'Clean' contacts). They require voltage to be applied to them in order for them to function.

**THEY ARE NOT INTERNALLY POWERED.**

**a: Coil Failure/High dP Remote Alarm Monitoring**

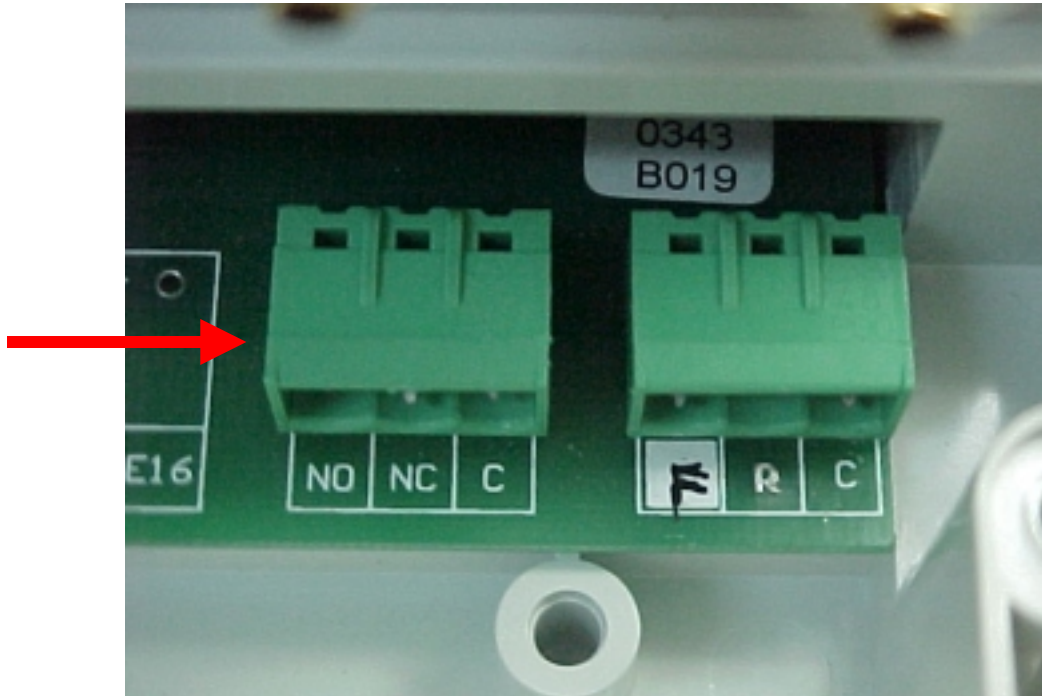

The arrow indicates the terminal connection for the remote alarm contact. This alarm is used to indicate any of the following two properties from a remote location.

- High dP
- Coil Failure

It is necessary to power this contact as it is a 'Dry' (or 'Clean') contact.

There are three contacts

C = Common

N.O = Normally Open

N.C = Normally Closed

A 24VDC supply is required to be connected to the Common (C) terminal in any of the three alternative ways to wire this contact.

**Choice 1. - Example set up**

If you wish for a light or buzzer (in a remote location) to illuminate or activate when an alarm occurs, connect the second wire to the Normally Closed (N.C) terminal as shown in Figure 7.

**Figure 7 - Remote Alarm Configuration 1**

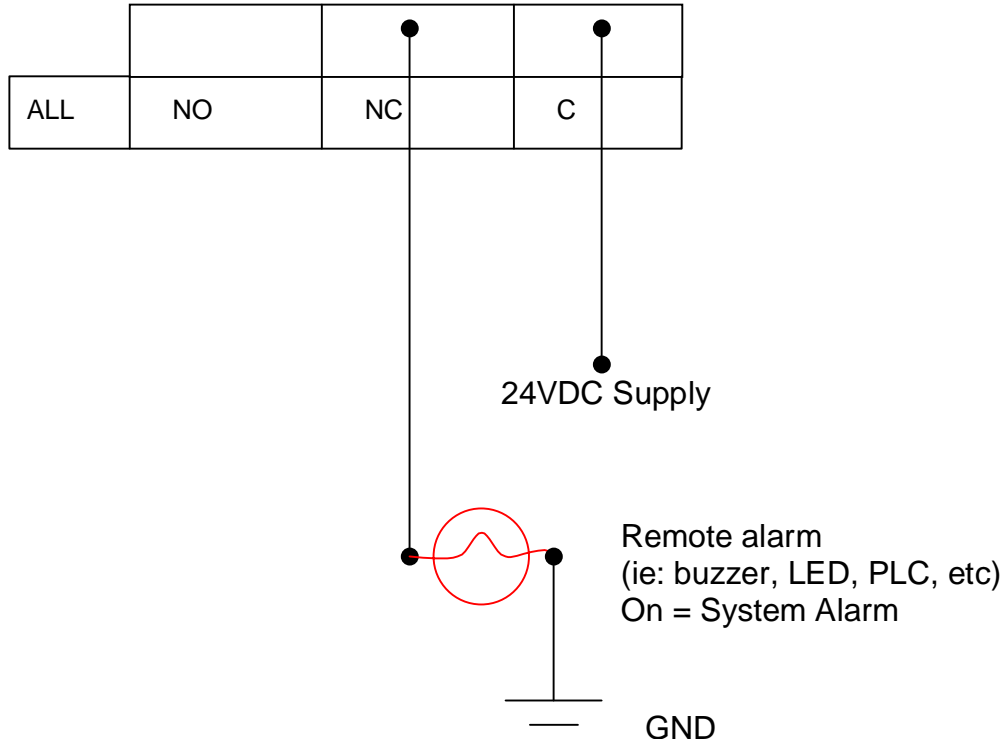

**Choice 2. - Example set up**

If you wish for a light (in a remote location) to illuminate at all times, and for the light to extinguish when an alarm occurs, connect the second wire to the Normally Closed (N.O) terminal as shown in Figure 8.

**Figure 8 - Remote Alarm Configuration 2**

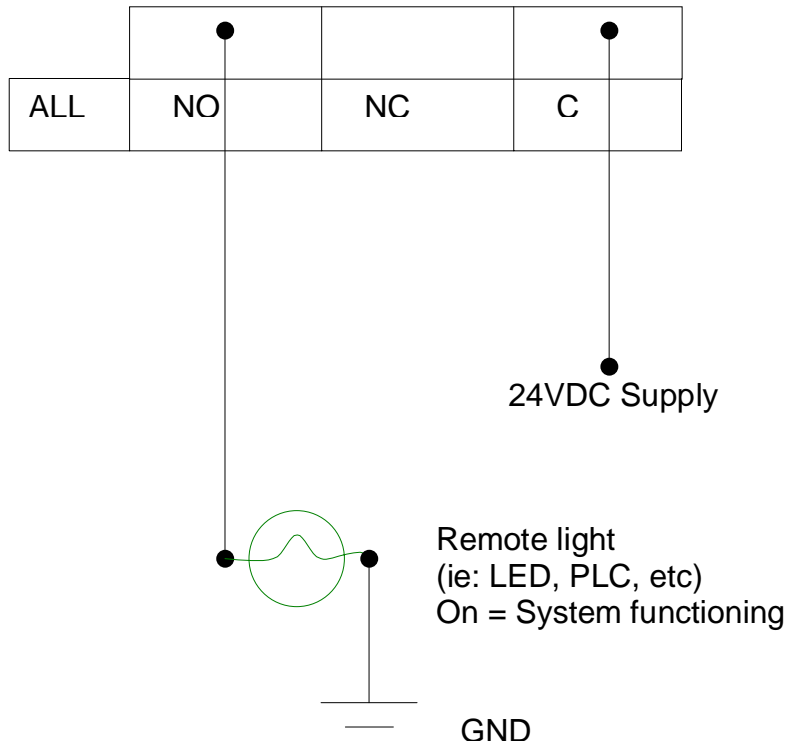

**Choice 3. - Example set up**

If you wish for a light (in a remote location) to illuminate at all times, and for the light to extinguish when an alarm occurs and an alarm light or buzzer to sound when an alarm occurs, connect the wires as shown in Figure 9.

**Figure 9 - Remote Alarm Configuration 3**

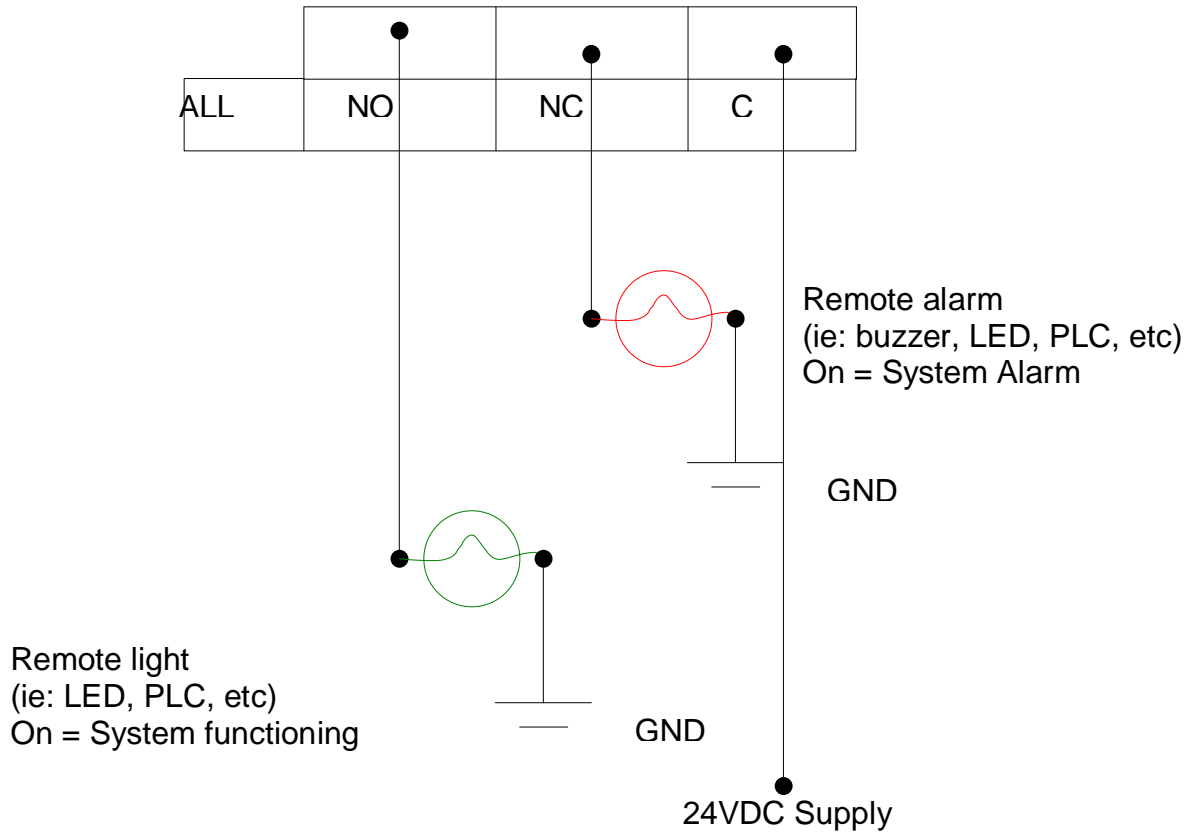

**b: Fan Contacts**

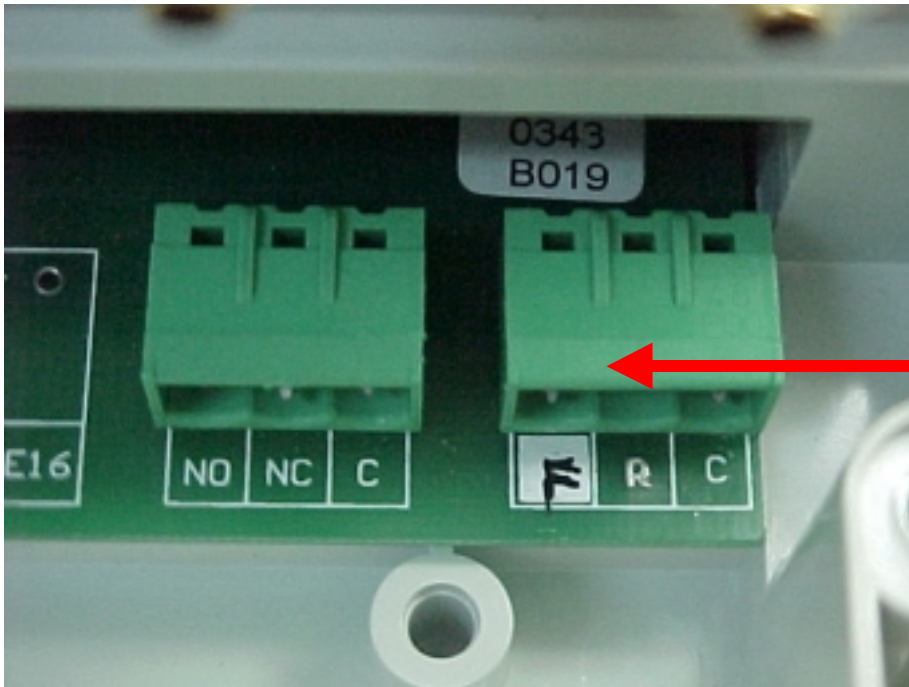

The arrow indicates the terminal connections for the Fan

It is not necessary to power this contact. If the Fan terminal is connected to ground, the unit will begin the After Cleaning Cycle. This terminal can be connected to a switch as shown in Figure 10.

**Figure 10 - Fan contacts**

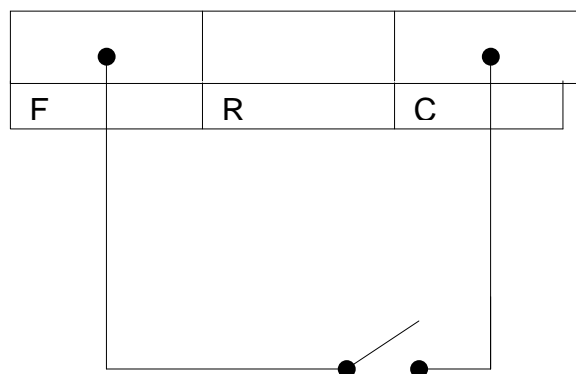

**c: Remote Contacts**

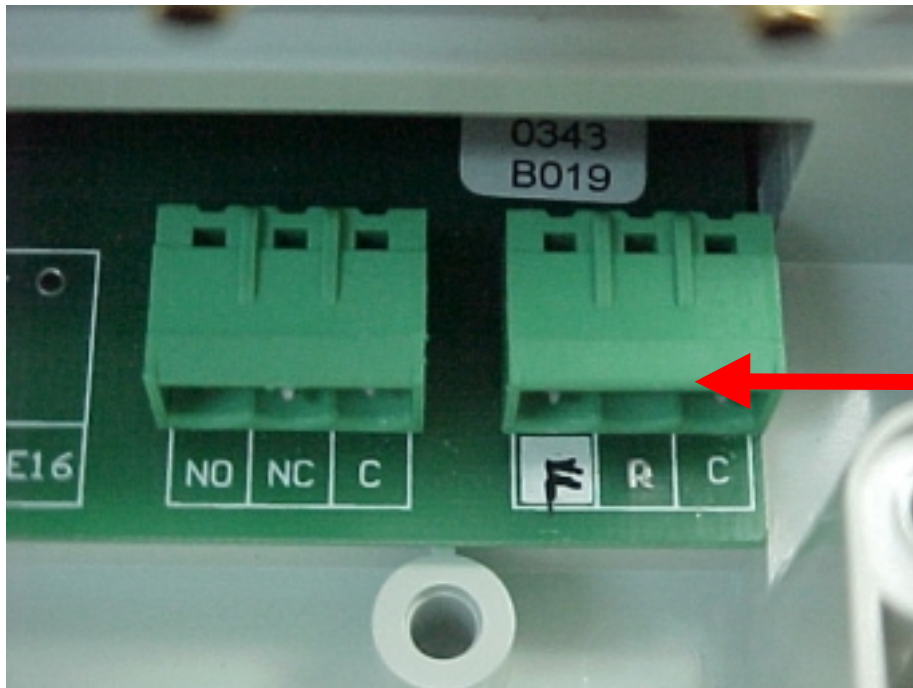

The arrow indicates the terminal connections for the Remote Contacts

It is not necessary to power this contact. If the Remote terminal is connected to ground, the unit will begin to operate. This terminal can be connected to a switch as shown in Figure 11.

**Figure 11 - Remote contacts**

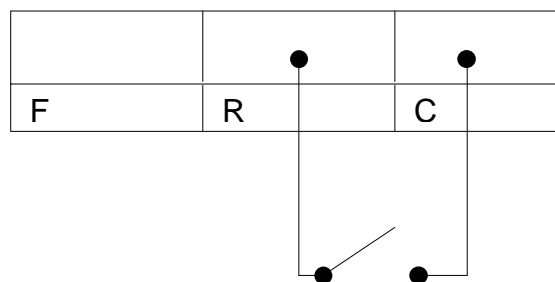

## OPERATION

### Electrical Pulse times

- Pulse Time (0.01 - 9.99 sec)
- Manual Pause Time (1 - 999 sec)
- Automatic Pause Time (1 - 999 sec)
- Operating Delta-P (0.01 - 250 kPa)
- Set Alarm Delta-P (0.01 - 250kPa)
- Shut Down Cleaning (0 - 99 cycles)

### User Operation

The LED panel has a maximum of 3 characters with 5 LED's that each have three states. The LED panel displays the relevant value of each of the 8 programmable variables. The particular programmable variable is indicated by use of the LED's.

Menu No	LED	State	Meaning of LED Panel Display
1	1	Steady ON	Manual or Auto Mode 0 = Manual mode, 1 = Automatic mode
2	2	Steady ON	Number valves on system An integer between 1 and 16
3	3	Steady ON	Pulse Time (0.01 - 9.99sec) The electrical on time of the valves
4	4	Steady ON	Manual Pause Time (1 - 999sec) The time that the system will pause for while in Manual mode
5	5	Steady ON	Automatic Pause Time (1 - 999sec) The time that the system will pause for while in Automatic mode
6	1	Flashing	Operating Delta-P (0.01 - 2.5kPa) The operating Delta-P which the operator wishes the controller to begin cleaning
7	2	Flashing	Set Delta-P Alarm (0.01 - 2.5kPa) Delta-P at which the high alarm is required
8	3	Flashing	Shut Down Cleaning (0 - 99 cycles) The number of cycles to be performed after the fan has been switched off

**Notes:** During the first cycle, check that all of the outlets function correctly (in the case that one or more do not operate, check the connections to the solenoids and that the correct number of valves is nominated in the program).

---

## **PRODUCT MAINTENANCE**

- Mount in environments of -10°C to + 50°C
- Do not directly expose to sunlight
- Do not mount directly to hot surfaces
- Protect from infiltrations of water and humidity
- Do not install on vibrating surfaces
- All the electrical connections including the wiring associated with the valves should not be in close proximity to wiring for other applications (for example from motor cables)